

R-454



4-Way Delay Valve

Features:

- Micro gap construction - snap action and no blow by
- Screwdriver slot needle adjustment deters tampering
- Balanced design allows speed control at exhausts

Performance:

Flow (SCFM @ 100 psig).....	9
Pilot pressure (psig) minimum.....	40
Temperature.....	32° to 180° F
Working pressure.....	0 to 150

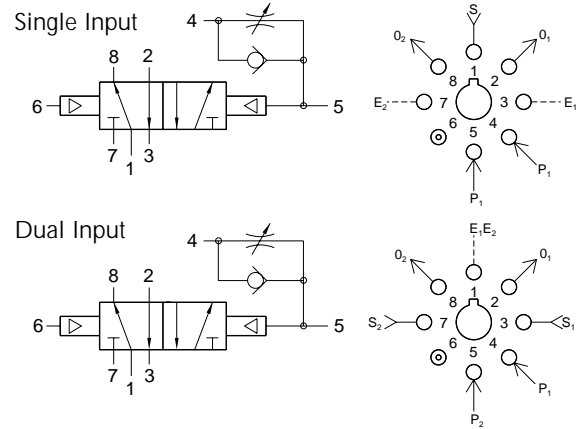

Description:

R-454 is a 4-way, double pilot, fully ported 5 port valve with an adjustable flow control valve interconnected to one pilot. A pilot signal input in port 4 will be delayed in before actuating the valve. The R-454 can perform all 2-, 3- and 4-way functions.

R-461



4-Way Valve, 6-Ported

Features:

- Indicator shows valve in shaded position
- Micro gap construction - snap action and no blow by
- Balanced design allows speed control at exhausts

Performance:

Flow (SCFM @ 100 psig).....	9
Pilot pressure (psig) minimum.....	40
Temperature.....	32° to 180° F
Working pressure.....	0 to 150

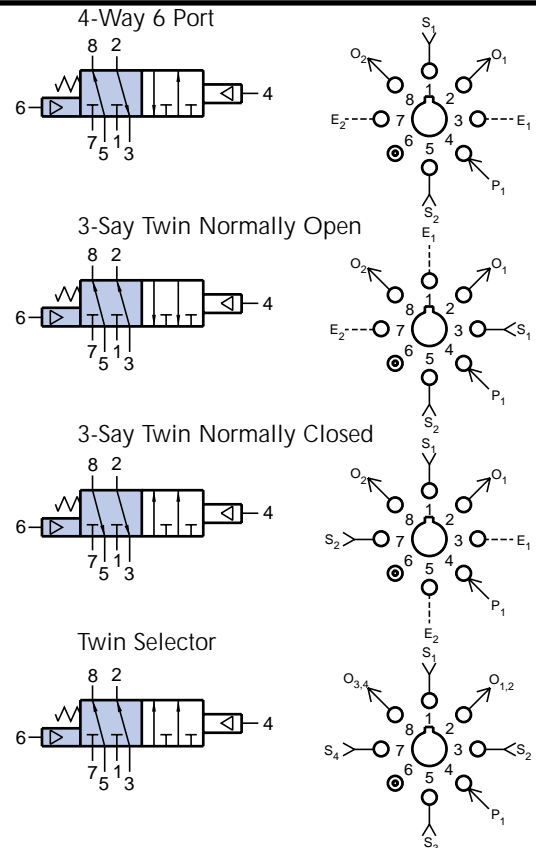

Description:

R-461 is a 6-ported, 4-way, spring return, fully ported, pilot operated valve. It is basically two fully ported 3-way valves with a common pilot. It can be used in a variety of applications including dual pressure operations with two independent inlets, outlets, and exhausts.